

Sight Glass Level Gauges Type 700.5413

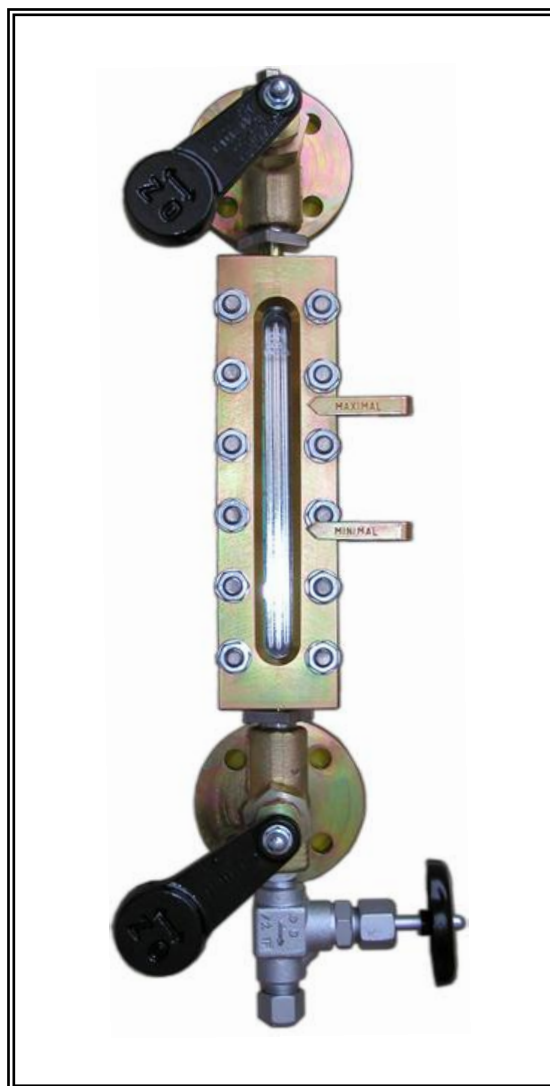

Operation and maintenance manual

1. Field of application

Sight glass level gauges type 700.5413

are for the direct visual indication of liquid levels, particularly also of steam condensate. Devices in bypass-technic support virtually all kind of media. After the principle of the communicating tubes the filling level will be transferred to the level gauge by level compensation between vessel and indicator. Gauge heads ensure a safe operation.

The devices may support all media and process data as long as the used materials are suitable. The type plate details have always to be taken into account. At operation with oscillation and vibration loads special types are used (specification!). Media with too much encrustation or deposition have to be avoided to ensure the readability.

Attention: If the medium is water and the danger of icing-up is given, the water for the purpose of avoidance to glass plate of damages, is to drain from sight glass level gauge or providing a heating.

2. Function

Reflex type - sight glass plates according to DIN 7081

Incident light is reflected at the reflex grooves of the sight glass plate covered by gas and is broken into the liquid in the part covered by medium. The liquid level is visible as a dark bar, the gaseous space as a silvery bar.

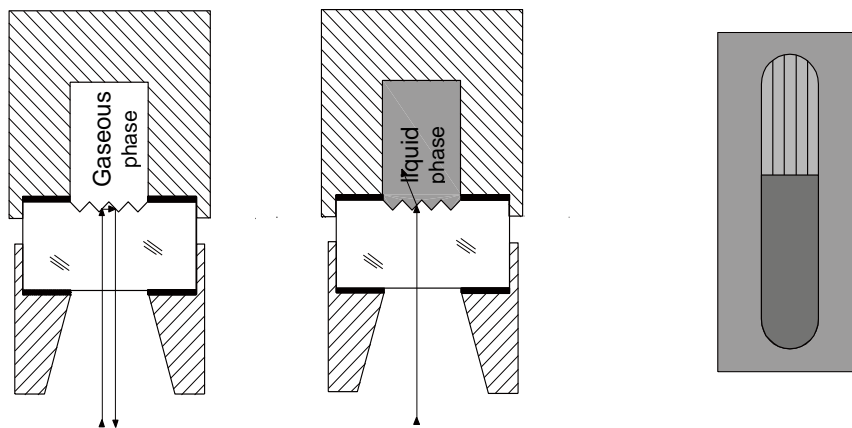

Schematic diagram: Trace of the rays in gaseous and liquid phase

3. Design of the divide

Basically all sight glass level gauges consist of the gauge body and gauge heads with safety ball check.

All representations are symbolic and can differ acc. to order specifications. Drain or vent are available as plugs, valves, flange studs etc. in various types, connections may be flanges, weld ends,.... Bridgings and number as well as size of the segments are affected by measuring length and requirements of the specification.

3.1 Ball check valves

The ball check is a safety facility used in all gauge heads. It prevents the flow out of the medium when glass or mica breakings occur while gauge heads are fully open.

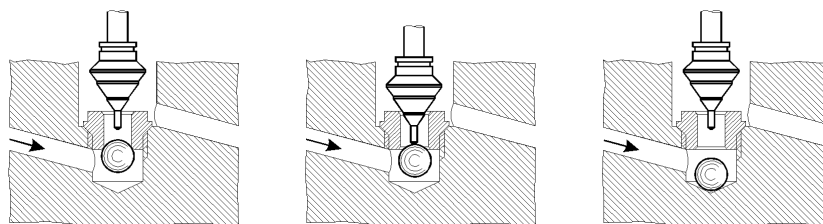

Ball check in action

Ball check at putting into service

Ball check in operation

There is a ball under the valve seat. As soon as the indicator gets leaky, the starting flow raises the ball from its hollow and pushes it against the valve seat ($\Delta p > 0,5 \text{ bar}$). Through this an unrestrained flow out of the medium is stopped as long as the pressure caused by the medium tightly presses the ball against the valve seat. The gauge heads can be closed then. After this the required exchange of glass tubes, glasses or mica sheets can be done.

Attention: During the closing operation the ball is pushed away from the seat short-timely and opens the seat cross-section for a moment. At this moment a small amount of the medium still can flow out! Because of this use protective clothing/spectacles if necessary!

3.2 Sight glass level gauges with glass plates according to DIN 7081

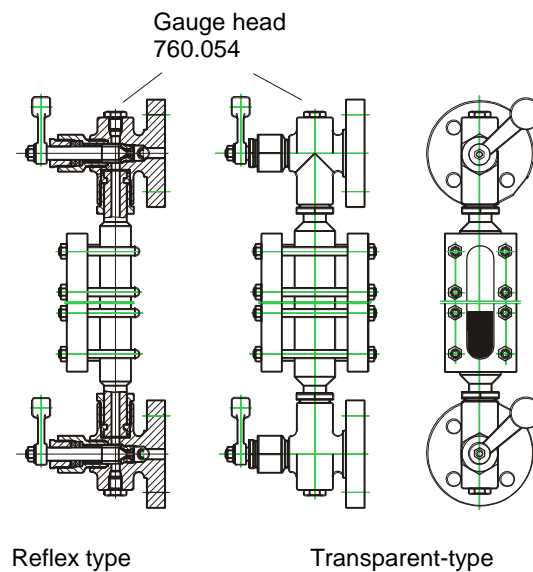

Type 700.54XX, PN 25, pivoted type

4. Putting into operation

The sight glass level gauges are manufactured in accordance with the publicly valid regulations and the specifications of the customer. You should check the conformance of the specifications with the requirements of the plant.

Before the assembly

- The devices have to be checked for perfect condition
- The mounting position (top, bottom) must be compared with the device type
- The center to center distance and connection type at the vessel have to be compared with the measures of the delivered device. Maximum deviation: +/- 1 mm.
- At the mounting it has to be ensured that the gauge is assembled free of canting or distortion.
- The seal plugs or covers of the openings of the gauge heads have to be removed before assembly.
- Corresponding work and measurement gears are to be provided; special tools aren't necessary

Attention: By suitable, site oriented measures it has to be guaranteed that shocks and/or vibrations (for outer plants take wind into account) aren't imparted to the device.

4.1 Mechanical assembly

- Remove covers from the connection flanges
- Assemble the completely assembled delivered indicators stressfree to the vessel connections
- At pivotable types the corresponding threaded joints must be opened approx. 2 turns and be fastened after the positioning of the indicator with approx. 15 Nm.
- The nuts of the glass covers have to be fastened in accordance to the picture with a torque wrench (particularly also before the first putting into service):

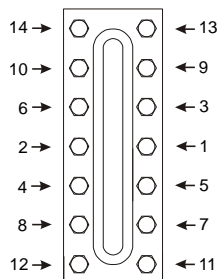

Screw	Norm	Size	Force [Nm]	Pressure Class
BOLT SCREW	DIN 938/939	M10	30	25/ CLASS 150

Pay attention that after mounting all accompanying stopping devices are closed.

4.2 General hints

The sight glass level gauges for liquids are normally delivered with gauge heads with simple shut-off or quick-closing (lever).

The sight glass level gauges are generally delivered with ball check.

At putting into operation open the gauge head's valves only as far as approx. ½ of the turn, so that the tip of the valve cone keeps the ball away from the valve seat to enable the medium flow into the gauge body. If the pressure balance with the vessel is accomplished, the valves can be opened completely.

Attention: To avoid stress – especially with hot media - the level gauge must be warmed up slowly. This action is not necessary if the medium has nearly environmental temperature.

4.3 Sight glass level gauge

Attention: When opening the drain valve: With dangerous media the drain valve may be opened only for a short time so that condensate forming can drain away. At this point **most caution** is advisable. Wear protective clothing/spectacles if necessary.

Sight glass level gauge with hand wheel shut-off gauge valves

- Slowly open the **upper** gauge valve for ½ - 1 turn to avoid that the ball check comes into action
- After pressure balance open completely
- Only then slowly open the **lower** gauge valve until level compensation has been reached
- After this open completely

- Check for tightness of all connections
- Tightening of the lid nuts is necessary, repeatedly in the first time after putting into operation, then 2-3 times within 24 h, until the torque remains constant

Warming up the gauge with the process medium

- Take into account pollution control regulations
- Attach condensate drain hose to the outlet of the drain valve and ensure safe drain
- Slowly open drain valve to avoid that the ball check comes into action
- Slowly open upper gauge head to avoid that the ball check comes into action
- Open the hand wheel valve $\frac{1}{2}$ - 1 turns
- Continue the warm-up process till the indicator nearly has operating temperature
- As soon as a clearly recognizable liquid level occurs, open all gauge valves fully so that the ball check can get effective at decompression in the indicator e.g. at glass breaking.
- After then open the upper gauge head, then close the drain valve again and start the filling process. Level gauges with heat tracing can be warmed up using this.

4.4 After putting into operation

The lid screws/nuts of the level gauges still have to be tightened several times since sealings and cushions of the glasses are settling with time.

4.5 Operating state

The gauge heads are fully open during the operation. In case of dangerous they have to be closed by the hand wheel.

5. Maintenance

Sight glass level gauges should be maintained in regular intervals. Control the glass plates for their condition, since some liquids, e.g. fully desalted water, may attack glass to a great extent.

Maintenance work - besides cleaning of the, gauge body and gauge valves - includes tightening of bolted joints and re-pressing of stuffing box packings.

5.1 Gauge body - cleaning

- Close gauge heads
- Open vent plug slowly until pressure balance with the environment has been reached
- Unscrew vent plug
- Take measures to collect or let off the medium
- Open drain plug or open drain valve and drain away medium
- Fill in medium or other permissible liquid provided that this is wholesome with the medium and the glasses from above and clean the gauge inside, if necessary with a brush.
- Screw in plug, close drain valve
- Put gauges into operation

5.2 Gauge valves - cleaning

Sight glass level gauge heads don't have any cleaning opening.

Cleaning can be therefore carried out only in the fully removed state.

This is generally carried out in the context of repair work.

Sealing - tighten sleeve nut of the packing carefully.

6. Repair

Attention: Glass exchange only should be carried out by trained staff because careful and clean work is required for this!
For security reasons we recommend to use only original spare.

6.1 Glass exchange

Attention: At every glass exchange it has to be respected that you don't damage the sealing surface! Furthermore it has to be checked before the assembly whether the correct glass size and the required glass quality is used (Preferrably borosilicate quality in accordance with DIN 7081).

- Depressurise vessels.
- Let medium drain away (take into account pollution regulations)
- Unscrew the lid nuts.
- Lift the lid.
- Remove faulty glasses and loose sealing parts.
- Clean sealing area (do not use sharp-edged tools!).
- Insert the new sealing into the sealing area.
- Insert the cushion with the glass into the lid.
- Insert reflection glasses with the grooves in direction to the liquid channel.
- The glasses must have clearance in the lid to all sides.
- Put on the lid over the bolts again.
- Tighten the nuts. Carry out tightness check.
- Tighten the nuts in intervals of 24 hours with torque screw wrench

Provided that the sight glass level gauges are equipped with mica protection or corrosion protection devices (FEP), those are put in front of or behind the glass corresponding with the above mentioned instructions.

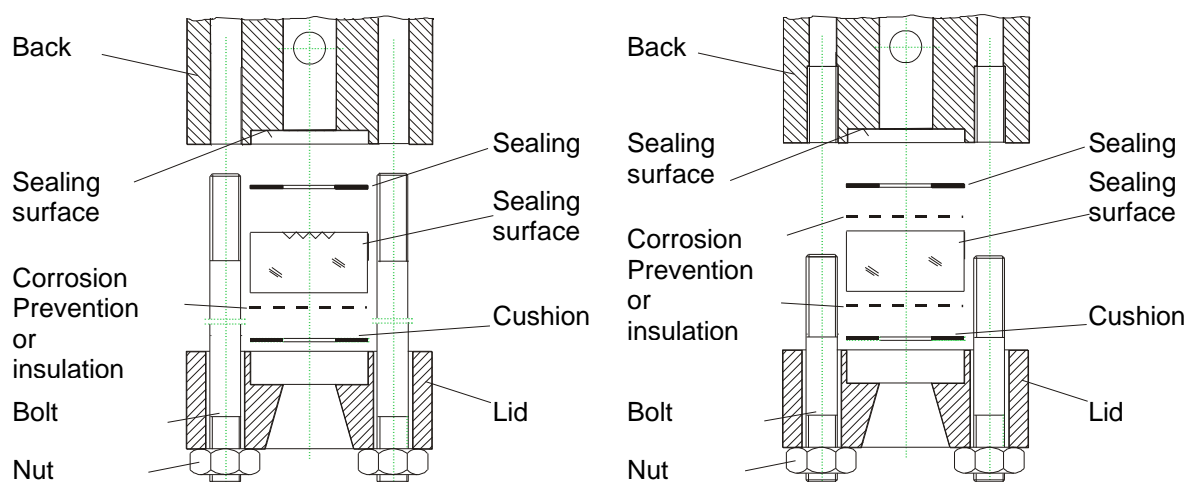

6.2 Gauge heads

Gauge heads may be equipped with flange connections, welding ends or thread.

- **It is recommended that repair of valves is done by the supplier.**
- **Repair work done by the plant operator himself shall be carried out only by trained specialist staff which has provably experience with such work. The functional safety of the shut-off devices must be ensured by plant operator authorities after the work. As support for the repair detail drawings and parts lists can be requested.**

760.054 PN 25

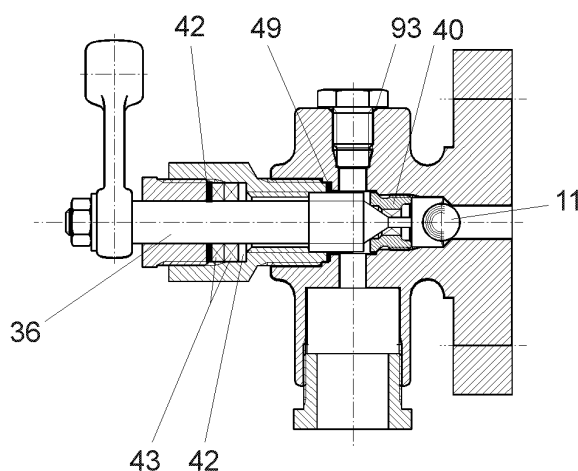

Part	Name
11	Ball
36	Spindle
40	Seat
42	Gasket
43	Graphite-Packing, pressed
49	Sealing bonnet
93	Plug

7. Safety notes

- The plant operator must have complete knowledge about the function of the sight glass level gauges. Otherwise he has to obtain special information from the manufacturer
- To prevent injuries protective measures shall always be taken like:
 - Carry safety goggles
 - Wear gloves
 - Wear protective clothing, breath protection at dangerous media
- For the general safety in the case of breakdowns as well as at maintenance works we recommend, to add a shut-off device between vessel and gauge head.
- To ensure early diagnosis of damages the level gauges have to be checked visually in regular intervals for leaks and glass attacks
- The maintenance intervals must be adapted to the operating conditions
- It is urgently required that all work is carried out by trained staff for security reasons

8. Behaviour in case of trouble

Attention: In case of a leakage during the operation (leaky packings, broken glass, faulty sealings) the level gauge has to be shut off from the vessel immediately